

DIGITAL PROCESSING



MULTIFUNCTION



MONITORING AND METERING



MODULAR ARCHITECTURE



SOFTWARE PC

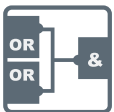

CONTROL FUNCTIONS



COMMUNICATION



MECHANICAL CHARACTERISTICS



■ GENERAL FEATURES

The **PRO-Plus** family is the Thytronic last generation of protective devices built on a common platform.

The compact size, the various assembly possibilities and the availability of measuring inputs suitable for 1 A and 5 A rated current, enable the relays to be adapted to different system layouts. It represents the final solution for the overall protection of distribution, utility substations and industrial networks whatever the voltage level.

The system comprises a basic unit which may be flush mounted in the traditional way (stand-alone) or with a separate operator panel.

Optional external modules may be added to enhance its comprehensive basic protective functions; the high-speed serial bus has been designed specially to ensure maximum reliability and efficiency. Due to the modularity of the software structure, all functions of the remote devices (output relays, LEDs, blocking circuits, etc.) may be programmed transparently by the operator.

To increase operational flexibility, the normal status and reset modes may be independently programmed for each output relay.

Each output relay may be freely assigned to the start, trip or alarm status of one or more thresholds for the several functions, in accordance with a programming tripping matrix.

The front operator panel holds an LCD display, a keypad, an RS232 serial port and eight LED indicators:

- Green ON LED, normally powered to indicate properly operation or flashing when an error by self-test diagnostic checks has been found
- Yellow START LED, which indicates a threshold start
- Red TRIP LED, which indicates a threshold trip
- Five freely assignable red LEDs, which may be independently configured and assigned at start, trip or alarm status of one or more thresholds.



■ DIGITAL PROCESSING



Digital signal processing, together with a strong integration of protection, metering, control and communication functions led to the use of a high performance hardware platform: there is a 32-bit CPU and a DSP (Digital Signal Processor) for processing the measurement algorithms. Flash memories, together with the local communication interface, enables the firmware to be updated quickly and reliably. The measurement and digital filtering of the signals enables the relays to perform the main protective functions with extreme accuracy and repeatability.

■ INTEGRATION OF PROTECTIVE ELEMENTS



The **PRO>N** family is organized in protective packages according to the commonly power system configuration (medium voltage distribution/ industrial and generation):

- Feeders and buses for primary and secondary distribution.
- Transformers, motors and generators.
- Utilities interconnection & dispersed generation systems.

Integration of multiple elements increases reliability of the protection system thanks to the reduction in the number of separate elements subject to failure: this maximize availability and reliability and meanwhile reduces the amount of panel wiring and costs.

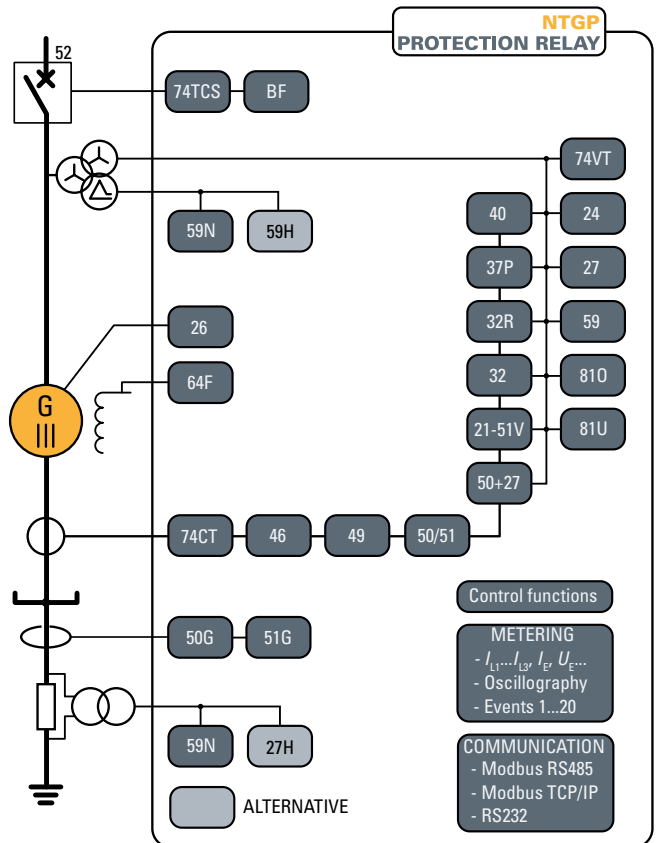

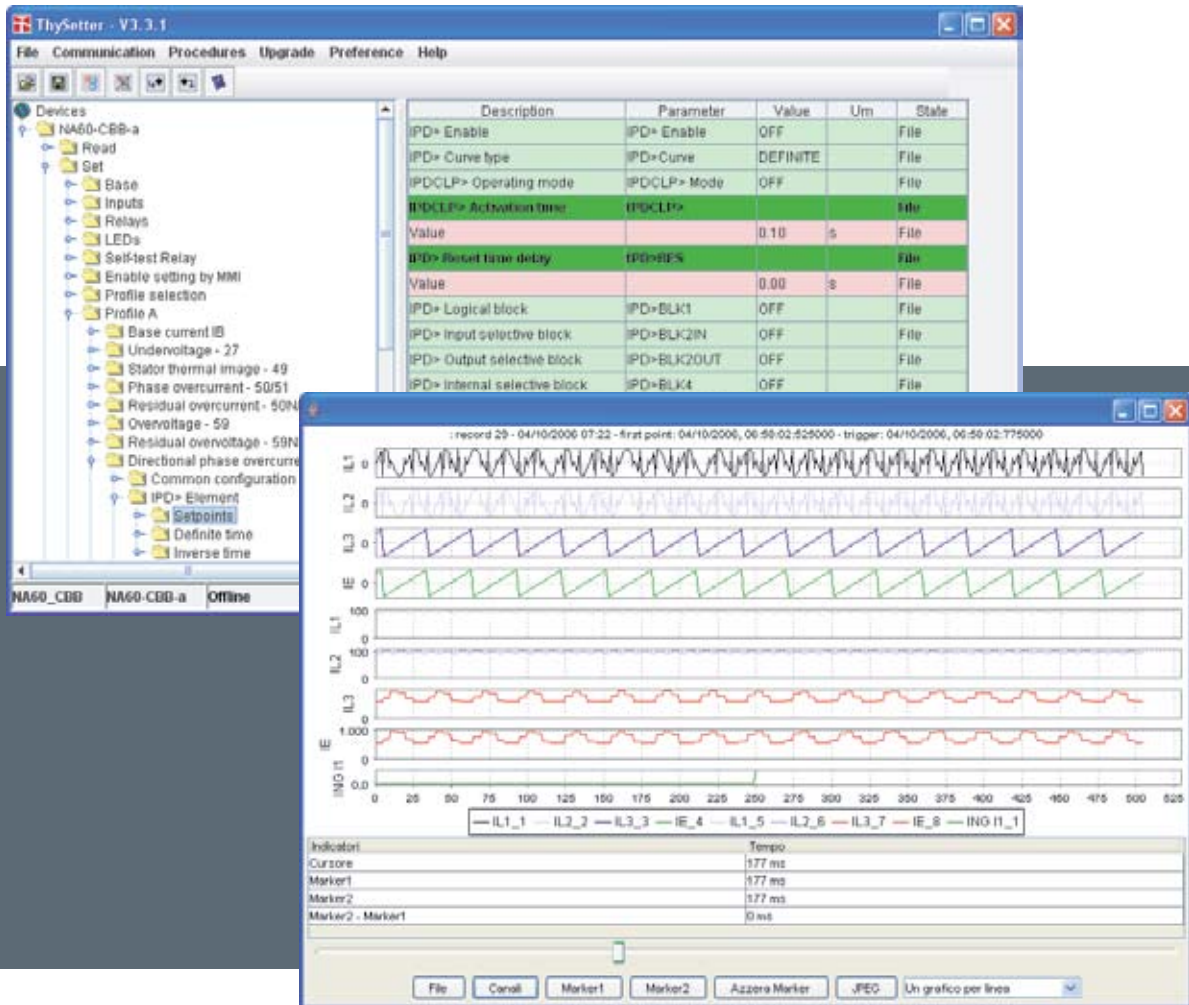

■ MONITORING AND METERING



The sequence of events logging and the recording of the waveform capture, provide the user with all of the useful information on the electrical network status.

This features allow continual and full monitoring in normal operation as well as in the event of a system fault.

High accuracy measurements may replace measuring instruments and transducers.

Direct measurements

For every input channel, the amplitude (RMS), phase and period for the fundamental and harmonic components are provided:

- Frequency,
- Phase & residual currents and voltages,
- Harmonic components,
- Directional currents, etc.

Computed measurements

On the basis of the direct measurements, the following are processed: phase-to-phase voltages, residual voltage and current, sequence components, powers, impedances, energy, mean weighted values, (equivalent thermal current, maximum RMS value, fixed demand of RMS values of each of the three phase currents in a programmable time interval, rolling demand, etc...).

Besides the input values, a lot of relevant information are available;

i.e: tripping counters, number of CB close commands, duration of the CB open and close operation, number of automatic reclosing commands, date and time, relay ID data, identification code, serial number, firmware version, rated parameters, etc.

Event storage

Several useful data are stored for diagnostic purposes; the events are stored into a non volatile memory.

They are graded from the newest to the older after a ThySetter command.

• Sequence of Event Recorder (SER)

The event recorder runs continuously capturing in circular mode the last three hundred events upon trigger of binary input/output or any setting change. Event cause, counter and time stamp are recorded for every event.

• Sequence of Fault Recorder (SFR).

The fault recorder runs continuously capturing in circular mode the last twenty faults upon trigger of binary input/output and/or element pickup (start-trip). Fault cause, counter, time stamp and meaningful measures are recorded for every fault.

• Trip counters.

Digital Fault Recorder (Oscillography)

Upon an adjustable trigger (start/trip, binary input and/or Thy-Setter command), the relay records in COMTRADE format:

- Oscillography with instantaneous values for transient analysis.
- RMS values for long time periods analysis.
- Logic states (binary inputs and output relays).

MODULAR DESIGN



An innovative concept of hardware upgradeability through auxiliary modules and an high-speed serial bus enables the user to adapt the protections to various system needs.

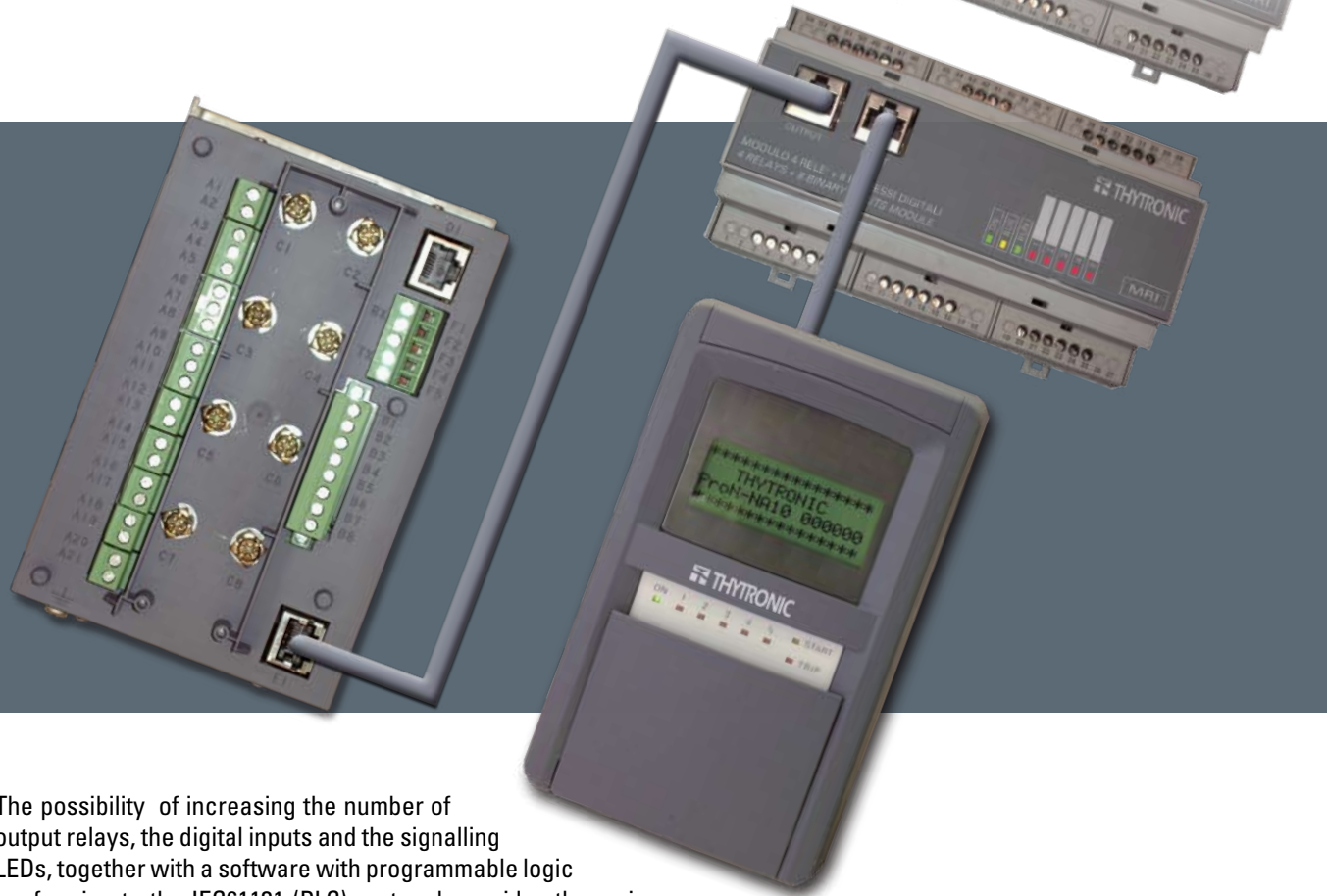

The possibility of increasing the number of output relays, the digital inputs and the signalling LEDs, together with a software with programmable logic conforming to the IEC61131 (PLC) protocol, provides the main switchgear automation and control functions. Besides the I/O expansion modules, additional modules for 4...20 mA output converters, Pt100 thermometric inputs probes and blocking circuits to achieve enhanced reverse interlocking systems, are available. The modular structure enables easy enhancement of the system via upgrades of in-service relays.

PC SOFTWARE



ThySetter, a parameter setting and configuration software, provides a simple and effective graphical user interface for:

- Displaying and modifying the setting data.

- Displaying the device configuration.
 - Displaying the waveform capture recordings.
 - Programmable logic compilation (PLC)
 - Saving the variables measured and setting variables in files.
 - Importing and exporting the data in text or Windows format.
- ThySetter software is developed in JAVA and ensures fully operating system independence.

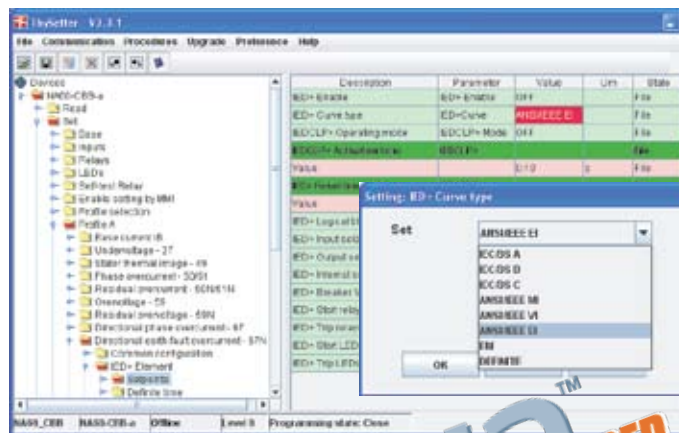

Java GET POWERED.

■ CONTROL AND MONITORING FUNCTIONS

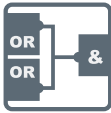

- Activation of multiple set point profiles.
- Remote reset.
- CT and VT monitoring.
- Logic selectivity.
- Cold load pickup (CLP).
- Automatic reclosing (79).
- Circuit breaker failure (BF).

□ Self test diagnostic

The run-time testing feature ensures that the relay will provide proper and reliable protection.

Main checks concern:

- Power supply.
- Output relays coils.
- CT and VT secondary.

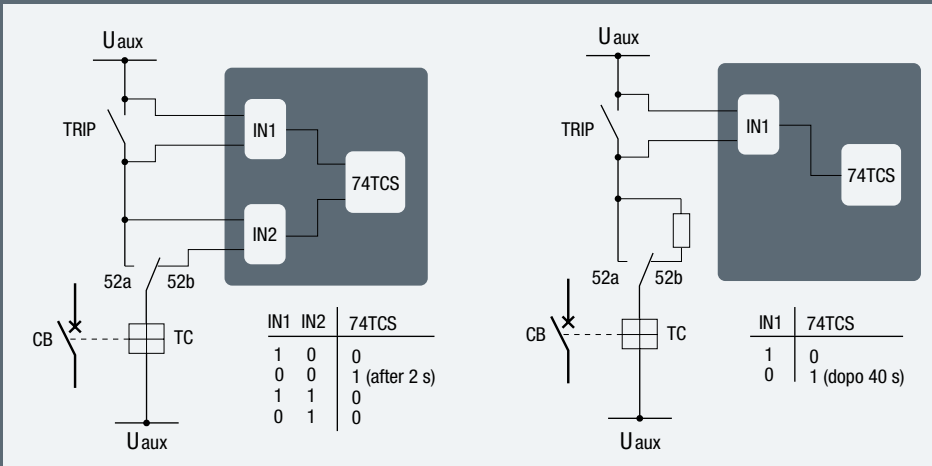

TRIP CIRCUIT SUPERVISION

- Trip circuit supervision (74TCS).
- Stabilization during transformer energization (INRUSH).
- Synchronization.
- CB control and monitoring.

- Blocking circuit (breaks or short circuits on the pilot wires).
- Non-volatile memory.
- Circuit breaker status.
- Watchdog.
- Data base and communication CRC.

□ Programmable logic

User defined logic must be customized in accordance with the IEC61131-3 protocol. The logic may complete or replace the supervision functions normally included in the switchgear control and executed by programmable logic controllers (PLC).

In addition to the elementary logic (OR, AND, NOT, XOR,...), further functional blocks are supported:

- Timers.
- Sequential logic (flip-flops...).
- Counters.
- Comparators.
- Selector switches.

Each trigger can be set on positive/negative transition of events or binary inputs.

IEC61131-3 standard intrinsically introduces the software quality concepts in relation to:

- Comprehensibility.
- Reusability.
- Testability.
- Maintainability.
- Life cycle.
- Fault identification.

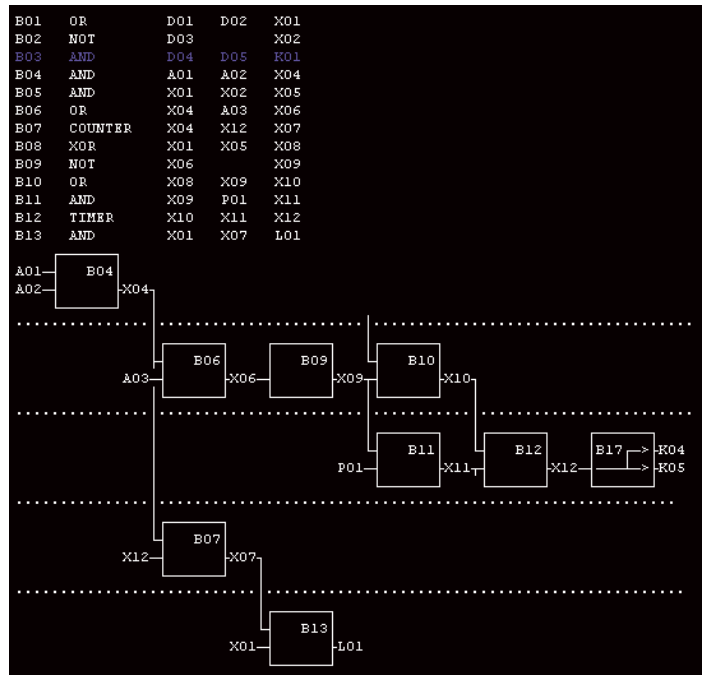

PROGRAMMABLE LOGIC CONTROLLER

■ COMMUNICATION



The evolution of the supervision and control systems in the electrical systems requires the possibility of setting up the protection relays as intelligent devices (IFD – Intelligent Field Devices) within communication networks consisting of general purpose devices such as PLCs or Personal Computers.

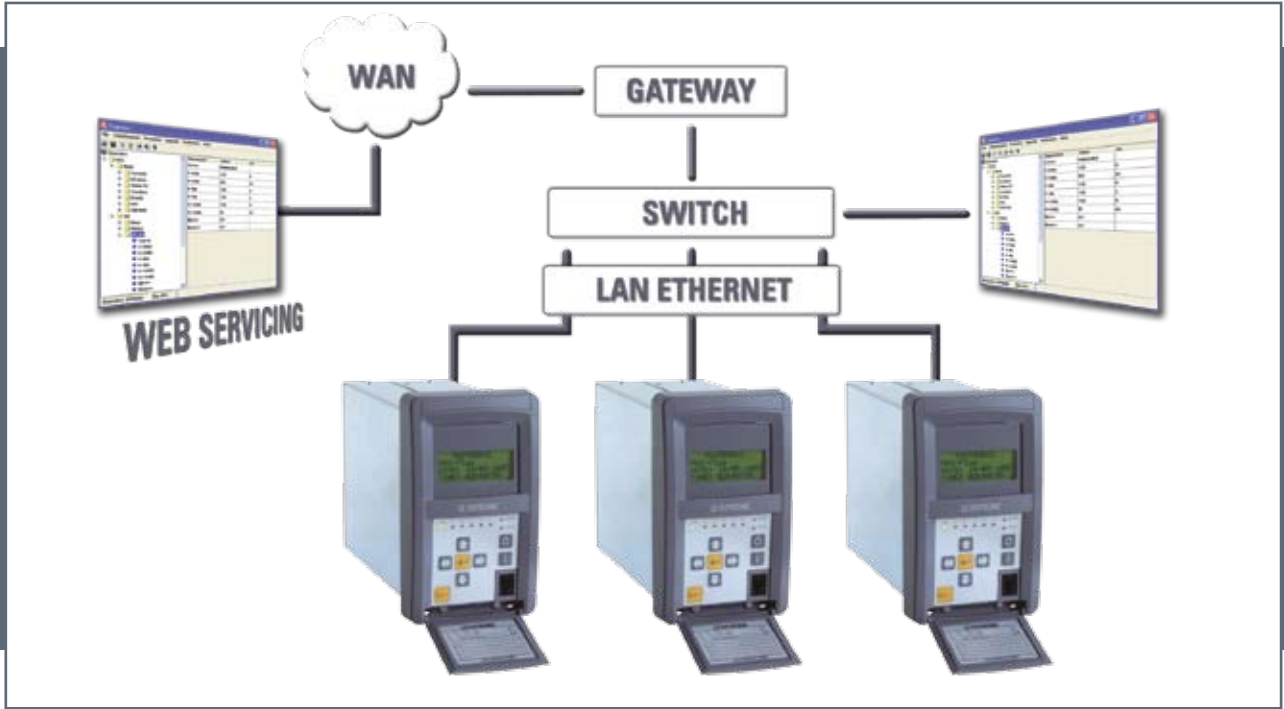

To meet this need, THYTRONIC has geared its development strategy towards the search for “open” solutions: **PRO>N** provides communication protocols based on Ethernet technology such as MODBUS TCP/IP and IEC61850. These protocols allow the use of a single field bus with all features required to control the electrical system as well as the process.

Main features are:

- Conformance to an international standard.
- High-speed updating of the variables sent.
- High communication reliability.
- Use of readily available commercial software that may be used in the most widespread programming environments.

In order to guarantee compatibility with traditional types of field bus, there are versions equipped with an RS485 interface with the Modbus RTU, IEC 60870-5 or DNP3 protocol.

The following communication ports are provided:

- One front RS232 serial port for connection to the Personal Computer.
- One rear serial port for connection to the auxiliary modules (I/O, Pt100,...) on the RS485 balanced line for extended connections, Thybus protocol.
- One rear Ethernet port with a copper or optical fibre interface.
- One rear RS485 serial port for connection to the field bus.

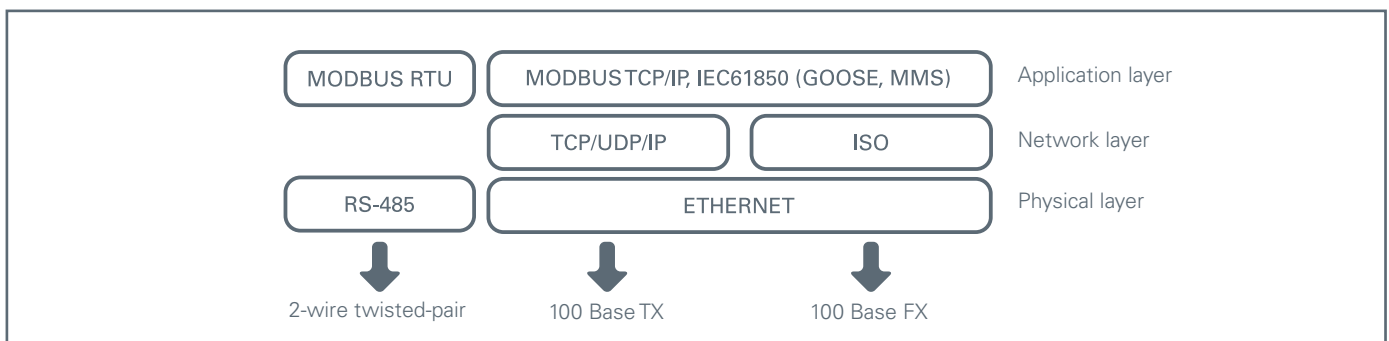

■ **MECHANICAL CHARACTERISTICS**



The **PRO>N** protection relays are housed inside metal cases suitable for various kinds of assembly:

- Flush mounting
- Projecting mounting
- With separate operator panel
- Rack.

The solution with projecting assembly and a separate operator panel is particularly suitable for limited in depth installations. The connections to the current signal inputs can be made by ring lugs and an insulating panel covering the terminals may be mounted for safety purposes. Removability is ensured to facilitate maintenance operations so that the electronic module can be replaced; this provides minimum downtime and maximum protection availability.

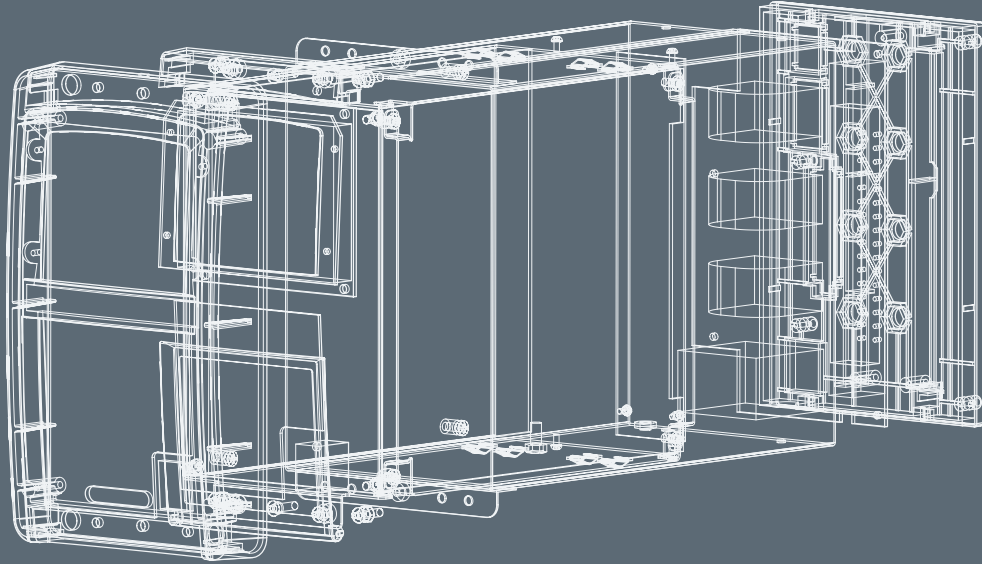

FRONT VIEWS

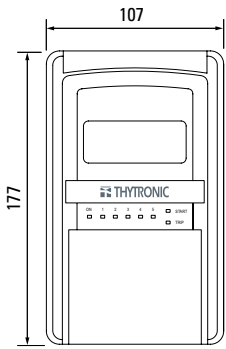

FLUSH MOUNTING

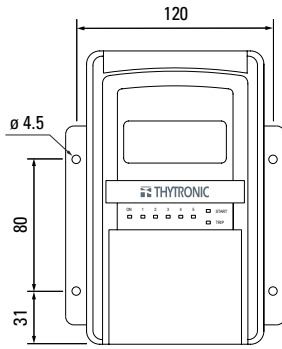

PROJECTING MOUNTING

REAR VIEWS

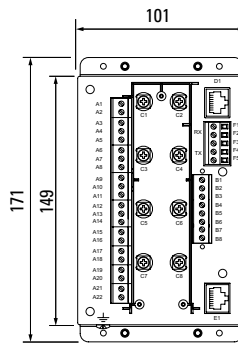

FLUSH MOUNTING

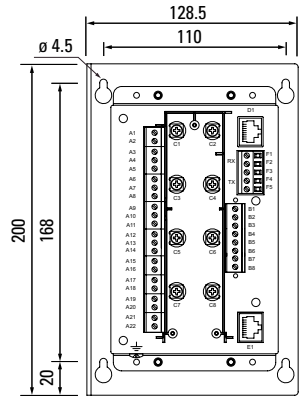

PROJECTING MOUNTING
(Separate operator panel)

SIDE VIEWS

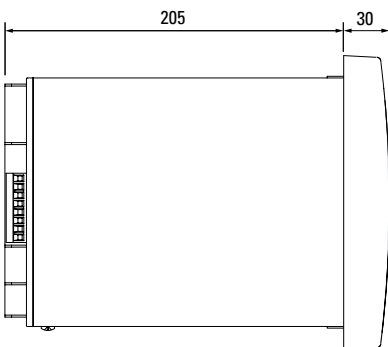

FLUSH MOUNTING



SEPARATE
OPERATOR PANEL

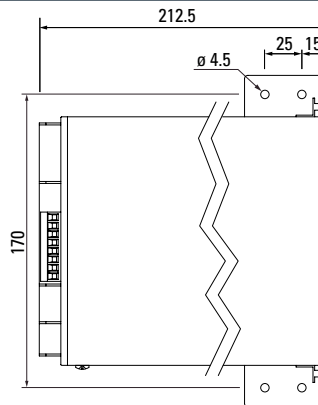

PROJECTING MOUNTING
(Separate operator panel)

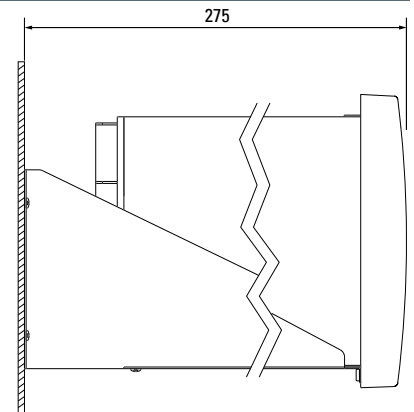

PROJECTING MOUNTING
(Stand alone)

POWER RELAY

AUTOMATIC RECLOSING DEVICE

SYNCHROCHECK DEVICE

SYNCHRONIZING DEVICE

PHASE & GROUND HIGH IMPEDANCE DIFFERENTIAL PROTECTION

BIASED OR HIGH IMPEDANCE RESTRICTED DIFFERENTIAL GROUND FAULT PROTECTION

FULL MULTIFUNCTION VOLTAGE AND FREQUENCY (PRO)

MULTIFUNCTION VOLTAGE AND FREQUENCY (BASE)

MULTIFUNCTION PROTECTION FOR BANK CAPACITORS/HARMONIC FILTERS WITH UNDER/OVERVOLTAGE ELEMENTS

MULTIFUNCTION PROTECTION FOR BANK CAPACITORS/HARMONIC FILTERS

MULTIFUNCTION PROTECTION FOR LARGE SIZE GENERATORS (PRO)

MULTIFUNCTION PROTECTION FOR SMALL AND MEDIUM SIZE GENERATORS (BASE)

MULTIFUNCTION PROTECTION FOR SYNCHRONOUS GENERATORS OR NOT SELF-STARTED SYNCHRONOUS MOTORS

BIASED DIFFERENTIAL FOR GENERATORS/MOTORS

MULTIFUNCTION PROTECTION FOR LARGE SIZE MOTORS (PRO)

MULTIFUNCTION PROTECTION FOR SMALL/MEDIUM SIZE MOTORS (BASE)

BIASED DIFFERENTIAL FOR TWO OR THREE SIDES

BIASED DIFFERENTIAL FOR TWO OR THREE SIDES

BIASED DIFFERENTIAL FOR TWO WINDING TRANSFORMERS

PHASE&RESIDUAL OVERCURRENT, PHASE&GROUND DIRECTIONAL, THERMAL IMAGE, PHASE UNDER/OVERVOLTAGE, RESIDUAL OVERVOLTAGE, AUTOMATIC RECLOSING

PHASE&RESIDUAL OVERCURRENT, GROUND DIRECTIONAL, THERMAL IMAGE, RESIDUAL OVERVOLTAGE, AUTOMATIC RECLOSING

PHASE&RESIDUAL OVERCURRENT, PHASE&GROUND DIRECTIONAL, THERMAL IMAGE, PHASE UNDER/OVERVOLTAGE, RESIDUAL OVERVOLTAGE

PHASE&RESIDUAL OVERCURRENT, PHASE&GROUND DIRECTIONAL, THERMAL IMAGE, RESIDUAL OVERVOLTAGE

PHASE & GROUND DIRECTIONAL OVERCURRENT, RESIDUAL OVERVOLTAGE

PHASE&RESIDUAL OVERCURRENT, GROUND DIRECTIONAL, THERMAL IMAGE, RESIDUAL OVERVOLTAGE

PHASE, NEGATIVE SEQUENCE&RESIDUAL OVERCURRENT, THERMAL IMAGE

PHASE&RESIDUAL OVERCURRENT

APPLICATIONS	NA10	NA20	NA30	NA40	NA50	NA60	NA70	NA80	NT10	NT20	NT30	NM10	NM20	NG10	NG20	NTGB	NTGP	NC10	NC20	NV10	NV20	ND10	ND20	NS10	NS20	NR10	NP10	
FEEDER	●	●	●	●	●	●	●	●	●	●	●											●	●			●	●	
BUS	●	●	●		●	●		●		●	●										●	●	●	●		●		
UTILITIES INTERCONNECTION	●		●			●		●													●	●						
TRANSFORMER	●	●	●	●	●	●		●	●	●													●	●				
MOTOR			●					●		●	●	●	●	●	●						●	●	●	●				●
GENERATOR			●	●		●		●	●	●				●	●	●	●				●	●	●	●	●			●
BANK CAPACITOR / HARMONIC FILTER																			●	●								●
PROTECTIVE FUNCTIONS																												
Underimpedance or voltage-controlled overcurrent (21-51V)																				□	□	□						
Overflux (V/Hz) (24)											□	□									□							
Synchro-check & synchronizing (25)																									□	□		
Temperature monitoring (26)										■	■										■							
Undervoltage (27)							□		□												□	□	□			□		□
Third harmonic Under/Overvoltage (100% stator earth fault) (27H-59H)																					□							
Directional active overpower (32P)																												□
Massima potenza reattiva (32Q)																												□
Directional reactive overpower (32R)																												□
Phase undercurrent (37)			□							□	□	□	□	□							□	□						
Reactive underpower (37P)																												□
Reactive underpower (37Q)																												□
Loss of field (40)																												
Negative sequence overcurrent (46)			□							□	□	□	□	□							□	□	□					
Thermal image (49)			□	□		□	□	□	□	□	□	□	□	□							□							
Inadvert energizing (50-27)																												
Phase overcurrent (50/51)																												
Residual overcurrent (50N/51N)			□	□	□	□	□	□	□	□	□	□	□	□							□	□	□	□				
High impedance restricted ground fault (87N)																								□				
Power factor (55)																												□
Overvoltage (59)																												
Residual overvoltage (59N)			□	□	□	□	□	□	□																	□		□
Rotor earth fault (64F)																												
Low impedance restricted ground fault (64REF)										□	□	□																
Maximum number of starting (66)													□	□														
Phase directional overcurrent (67)				□	□	□	□	□																				
Ground directional overcurrent (67N)				□	□	□	□	□	□																			
Automatic Reclosing (79)										□	□																	□
Underfrequency & overfrequency (81U) (81O)																												□
Frequency rate of change (81R)																												□
Vector jump (DPHI)																												
Differential protection for generators and motors (87G/87M)																												
Phase high impedance differential (87NHIZ)																												
Biased (87N) or high impedance (87NHIZ) restricted earth fault																												
Biased differential for transformer (87T)																												
Differential for transformers, generators, motors, short lines (87)																												
Voltage (90V) and frequency (90F) regulator																												

□ PRODUCTION MODEL ■ OPTIONAL □ ALTERNATIVE

POWER RELAY

AUTOMATIC RECLOSING DEVICE

SYNCHROCHECK DEVICE

SYNCHRONIZING DEVICE

PHASE & GROUND HIGH IMPEDANCE DIFFERENTIAL PROTECTION

BIASED OR HIGH IMPEDANCE RESTRICTED DIFFERENTIAL GROUND FAULT PROTECTION

FULL MULTIFUNCTION VOLTAGE AND FREQUENCY (PRO)

MULTIFUNCTION VOLTAGE AND FREQUENCY (BASE)

MULTIFUNCTION PROTECTION FOR BANK CAPACITORS/HARMONIC FILTERS WITH UNDER/OVERVOLTAGE ELEMENTS

MULTIFUNCTION PROTECTION FOR BANK CAPACITORS/HARMONIC FILTERS

MULTIFUNCTION PROTECTION FOR LARGE SIZE GENERATORS (PRO)

MULTIFUNCTION PROTECTION FOR SMALL AND MEDIUM SIZE GENERATORS (BASE)

MULTIFUNCTION PROTECTION FOR SYNCHRONOUS GENERATORS OR NOT SELF-STARTED SYNCHRONOUS MOTORS

BIASED DIFFERENTIAL FOR GENERATORS/MOTORS

MULTIFUNCTION PROTECTION FOR LARGE SIZE MOTORS (PRO)

MULTIFUNCTION PROTECTION FOR SMALL/MEDIUM SIZE MOTORS (BASE)

BIASED DIFFERENTIAL FOR TWO OR THREE SIDES

BIASED DIFFERENTIAL FOR TWO OR THREE SIDES

BIASED DIFFERENTIAL FOR TWO WINDING TRANSFORMERS

PHASE&RESIDUAL OVERCURRENT, PHASE&GROUND DIRECTIONAL, THERMAL IMAGE, PHASE UNDER/OVERVOLTAGE, RESIDUAL OVERVOLTAGE, AUTOMATIC RECLOSING

PHASE&RESIDUAL OVERCURRENT, GROUND DIRECTIONAL, THERMAL IMAGE, RESIDUAL OVERVOLTAGE, AUTOMATIC RECLOSING

PHASE&RESIDUAL OVERCURRENT, PHASE&GROUND DIRECTIONAL, THERMAL IMAGE, PHASE UNDER/OVERVOLTAGE, RESIDUAL OVERVOLTAGE

PHASE&RESIDUAL OVERCURRENT, PHASE&GROUND DIRECTIONAL, THERMAL IMAGE, RESIDUAL OVERVOLTAGE

PHASE & GROUND DIRECTIONAL OVERCURRENT, RESIDUAL OVERVOLTAGE

PHASE&RESIDUAL OVERCURRENT, GROUND DIRECTIONAL, THERMAL IMAGE, RESIDUAL OVERVOLTAGE

PHASE, NEGATIVE SEQUENCE&RESIDUAL OVERCURRENT, THERMAL IMAGE

PHASE&RESIDUAL OVERCURRENT

APPLICATIONS	NA10	NA20	NA30	NA40	NA50	NA60	NA70	NA80	NT10	NT20	NT30	NM10	NM20	NG10	NG20	NTGB	NTGP	NC10	NC20	NV10	NV20	ND10	ND20	NS10	NS20	NR10	NP10	
FEEDER	●	●	●	●	●	●	●	●		●	●										●	●	●	●		●	●	
BUS	●	●	●		●	●		●		●	●										●	●	●	●		●		
UTILITIES INTERCONNECTION	●		●			●		●		●	●										●	●		●				
TRANSFORMER	●	●		●	●	●		●	●		●												●	●				
MOTOR			●					●		●	●	●	●	●	●						●	●		●	●		●	
GENERATOR			●	●		●		●		●	●				●	●	●	●			●	●	●	●	●		●	
BANK CAPACITOR / HARMONIC FILTER															●	●			●	●								
CONTROL & MONITORING																												
Breaker failure (BF)	□	□	□	□	□	□	□	□	□	□	□	□	□	□	□	□	□	□	□	□	□	□	□	□	□	□	□	□
VTs monitoring (74VT)				□	□	□									□		□											□
CTs monitoring (74CT)	□	□	□	□	□	□	□	□	□	□	□	□	□	□	□	□	□	□	□	□	□	□	□	□	□	□	□	□
Trip circuit supervision (74TCS)	□	□	□	□	□	□	□	□	□	□	□	□	□	□	□	□	□	□	□	□	□	□	□	□	□	□	□	□
Cold Load Pickup	□	□	□	□	□	□	□	□	□	□	□	□	□	□	□	□	□	□	□	□	□	□	□	□	□	□	□	□
Second harmonic restraint	□	□	□	□	□	□	□	□	□	□	□	□	□	□	□	□	□	□	□	□	□	□	□	□	□	□	□	□
CB diagnostic	□	□	□	□	□	□	□	□	□	□	□	□	□	□	□	□	□	□	□	□	□	□	□	□	□	□	□	□
Multiple setting profiles	□	□	□	□	□	□	□	□	□	□	□	□	□	□	□	□	□	□	□	□	□	□	□	□	□	□	□	□
Logic selectivity	□	□	□	□	□	□	□	□	□	□	□	□	□	□	□	□	□	□	□	□	□	□	□	□	□	□	□	□
Sequential trip logic																	□	□										
Fault and event logging (SER & SFR)	□	□	□	□	□	□	□	□	□	□	□	□	□	□	□	□	□	□	□	□	□	□	□	□	□	□	□	□
Digital Fault recording (DFR)	□	□	□	□	□	□	□	□	□	□	□	□	□	□	□	□	□	□	□	□	□	□	□	□	□	□	□	□
Self-test	□	□	□	□	□	□	□	□	□	□	□	□	□	□	□	□	□	□	□	□	□	□	□	□	□	□	□	□
HARDWARE																												
N° 2 binary inputs + N° 6 output relays + N° 8 LEDs	□	□	□	□	□	□	□	□	□	□	□	□	□	□	□	□	□	□	□	□	□	□	□	□	□	□	□	□
N° 8 binary inputs + N° 8 output relays + N° 16 LEDs											□																	
N° 16 binary inputs + N° 16 output relays + N° 24 LEDs																					■							
Network module with Ethernet TX port (copper RJ45) + RS485 port	□	□	□	□	□	□	□	□	□	□	□	□	□	□	□	□	□	□	□	□	□	□	□	□	□	□	□	□
Network module with Ethernet FX port (optical fiber)	□	□	□	□	□	□	□	□	□	□	□	□	□	□	□	□	□	□	□	□	□	□	□	□	□	□	□	□
RS485 port	□	□	□	□	□	□	□	□	□	□	□	□	□	□	□	□	□	□	□	□	□	□	□	□	□	□	□	□
Auxiliary power supply 24-48 Vac/dc	□	□	□	□	□	□	□	□	□	□	□	□	□	□	□	□	□	□	□	□	□	□	□	□	□	□	□	□
Auxiliary power supply 110-230 Vac/dc	□	□	□	□	□	□	□	□	□	□	□	□	□	□	□	□	□	□	□	□	□	□	□	□	□	□	□	□
Nominal current 1/5 A selectable by DIP-switch	□	□	□	□	□	□	□	□	□	□	□	□	□	□	□	□	□	□	□	□	□	□	□	□	□	□	□	□
Flush, Projecting and 19-inch "4U" rack mounting	□	□	□	□	□	□	□	□	□	□	□	□	□	□	□	□	□	□	□	□	□	□	□	□	□	□	□	□
19/2-inch "3U" rack mounting										□																		
19-inch "3U" rack mounting											□										□	□						
COMMUNICATION																												
Modbus RTU RS232 protocol	□	□	□	□	□	□	□	□	□	□	□	□	□	□	□	□	□	□	□	□	□	□	□	□	□	□	□	□
Modbus TCP/IP protocol (network board must be provided)	■	■	■	■	■	■	■	■	■	■	■	■	■	■	■	■	■	■	■	■	■	■	■	■	■	■	■	■
Modbus RTU RS485 / IEC 870-5-103 / DNP3 protocol	□	□	□	□	□	□	□	□	□	□	□	□	□	□	□	□	□	□	□	□	□	□	□	□	□	□	□	□

□ PRODUCTION ■ OPTIONAL



A PERSONALISED SERVICE OF THE PRODUCTION, A RAPID DELIVERY, A COMPETITIVE PRICE AND AN ATTENTIVE EVALUATION OF OUR CUSTOMERS NEEDS, HAVE ALL CONTRIBUTED IN MAKING US ONE OF THE BEST AND MOST RELIABLE PRODUCERS OF PROTECTIVE RELAYS. FORTY YEARS OF EXPERIENCE HAS MADE STANDARD THESE ADVANTAGES THAT ARE GREATLY APPRECIATED BY LARGE COMPANIES THAT DEAL ON THE INTERNATIONAL MARKET. A HIGHLY QUALIFIED AND MOTIVATED STAFF PERMITS US TO OFFER AN AVANT-GARDE PRODUCT AND SERVICE WHICH MEET ALL SAFETY AND CONTINUITY DEMANDS, VITAL IN THE GENERATION OF ELECTRIC POWER. OUR COMPANY PHILOSOPHY HAS HAD A POSITIVE REACTION FROM THE MARKET BY BACKING OUR COMMITMENT AND HENCE STIMULATING OUR GROWTH.